

BROWN & HOLMES (Tamworth) LTD

Precision Workholding and Machining

INDOOR AIR QUALITY SOLUTIONS

for Machining Applications

MistBuster® Range



Air quality solutions from people who care

Brown and Holmes specialises in workholding solutions, subcontract machining and related products. Conveniently based in Tamworth in central England, we supply customers across the world including UK, Europe, the Middle East, Asia and United States of America.

We have built an international reputation for quality work holding solutions, mechanical handling, precision machining and sub-contract machining services as well as for the products we supply.

Often working with customers to turn initial ideas and concepts into solutions we offer a full turn-key service customised to meet their requirements and budgets. Enabling us to do this, we have our own design team and specialist manufacturing sites. We also work with customers' shop floor teams on their implementation across the globe as well as providing full technical backup, support and maintenance programmes.



- We build and strengthen our working relationship with you based on providing honest air cleaning system performance data.

Products

We design and manufacture our own high-quality air cleaning systems, including sheet metal fabrication, using state-of-the-art equipment and lean manufacturing that:

- Provides quality control
- Increases manufacturing speed and product delivery time.

Our people, processes and products

People

- Call our engineers, managers and air quality experts and receive prompt answers to your questions.
- Engineers specialized in:
 - Design
 - Applications
 - Product development
 - Product engineering
- We'll go the extra mile for you — before and after the installation of your new air cleaning system.

Processes

- Our consultative selling approach ensures we first understand your needs and then recommend a system that will solve your indoor air quality problems.
- The range of MistBuster® products, enables us to recommend the ideal air cleaning system for your application.

Air cleaning systems that work for you

At Brown & Holmes our goal is to tailor an indoor air cleaning system that provides solutions for your machining application problems. Our systems deliver these benefits:

- Protect employees by reducing exposure to hazardous airborne mist, smoke and metal particles produced by industrial machining applications.¹
- Comply with indoor air quality standards and governmental regulations.
- Protect equipment.
- Reduce maintenance and operation costs.
- Meet employee and customer expectations for a clean, healthy and safe working environment.
- Improve employee retention and recruitment.



Our three-step process

We use a three-step process to learn about your unique needs and help you select, size and install the right machine tool mount and MistBuster® unit for your shop or facility.

1. What are the contaminants?

- Mist
- Smoke
- Metal or other particles

2. How do we capture the contaminants?

- Electrostatic filtration (MistBuster® Range)
- Media filtration (MistBuster® Range)
- What are the benefits, trade-offs and your personal preferences for each type of technology?

3. What air cleaning system can we use?

- MistBuster® Range
- Tailored solution using both The Range

How electrostatic filtration works

Electronic air cleaner systems use one or more permanent electronic collector cells or filters featuring electrostatic precipitation technology to collect and remove airborne mist, smoke and metal particles generated by machining applications.

An electronic collector cell is composed of an ionizing or charging section and a collection section. Incoming contaminant particles pass through an intense ionization field in the charging section. The ionization causes the particles to lose electrons and acquire a positive electrical charge.

In the collection section, positive-charged metal plates or fins repel the positively charged particles and alternating grounded fins attract the positively charged particles that coalesce and form droplets. Contaminated droplets remain trapped on the grounded fins until the collector cell is washed.

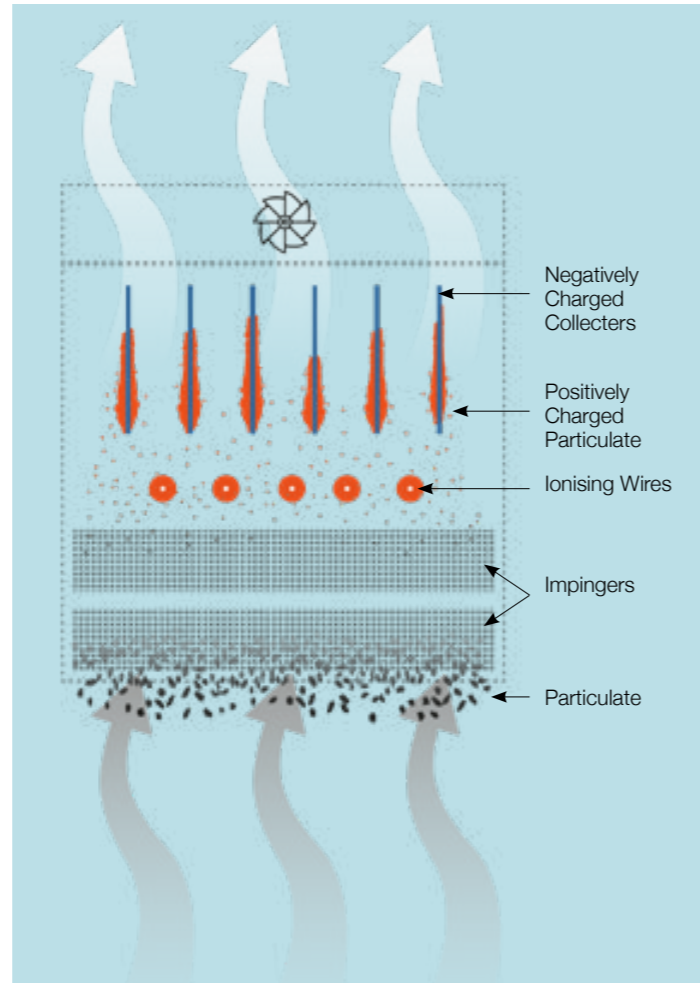

How media filtration works

Media filtration air cleaning systems for machining applications generally use a disposable fabric-type filter to efficiently capture smoke, mist and metal particles. A high efficiency particulate air (HEPA) filter is a common example of a media filter, although filters are available in a wide variety of media efficiencies, styles and materials. Air filtration mechanisms include straining, inertial impaction, interception and diffusion.

STRAINING

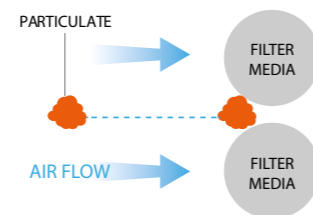

INERTIAL IMPACTION

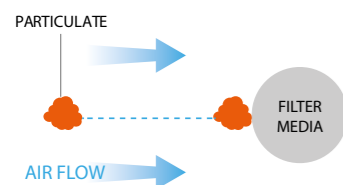

INTERCEPTION

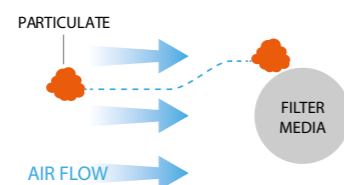

DIFFUSION

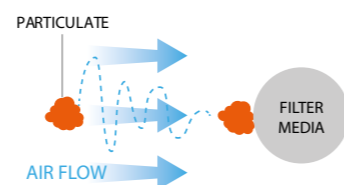

Highly efficient capture of harmful airborne contaminants

MistBuster® is a family of industrial air cleaning systems for the source capture of mist and smoke generated by today's machine tools.

The MistBuster® product line is highly efficient at collecting and removing dangerous airborne machining application contaminants using electrostatic precipitation and/or media filtration technologies. Options include: disposable high efficiency particulate air (HEPA) filters; extended service filter (ESF) media filters; and carbon modules for enhanced filtration and odor control.



Product line features

- Electrostatic precipitation air cleaning systems provide 97.8%–99.6% collection efficiency on all submicron particles. An optional HEPA media filter supplies up to 99.97% collection efficiency.
- Media-based air cleaning systems provide 95% minimum efficiency reporting value (MERV) 14 and 15 filter ratings.
- Electrostatic precipitation systems offer various combinations of the long-life Advantage™ and high-efficiency electronic collector cells.
- Electrostatic precipitation air cleaning systems allow you to easily switch between water-soluble or oil-based machine tool coolants.
- Our air cleaning systems have variable and controllable airflows ranging from 500 to 1,650 CFM and require minimal maintenance in wet environments.

Machining applications

- Metal machining
- Grinding/polishing
- EDM mist collectors
- Works with Water based & Neat Oil applications

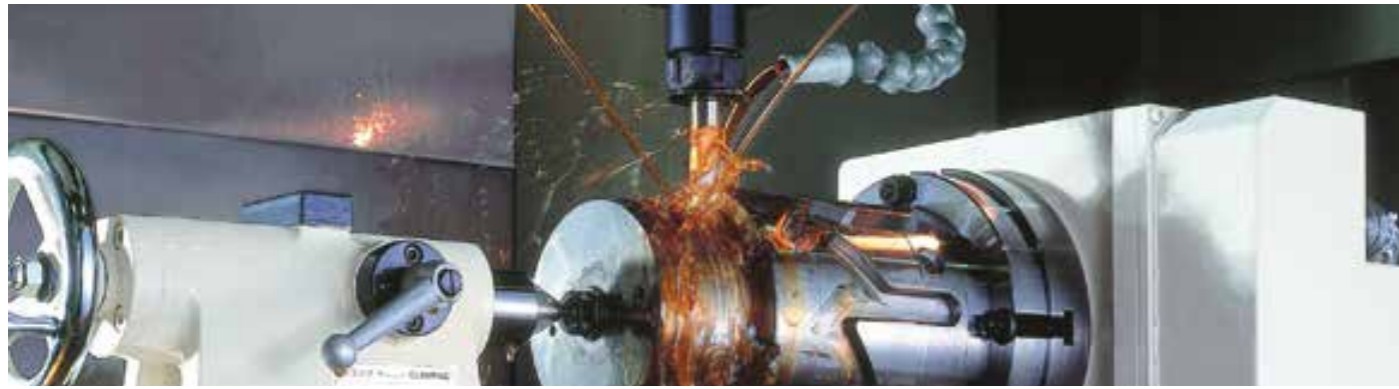

	ELECTROSTATIC				MEDIA	
MODEL	MB500	MB850 COMPACT	MB850	MB2000	MB500 MEDIA	MB INFINITY
Airflow	Variable to 500 CFM	Variable to 850 CFM	Variable to 850 CFM	Variable to 1,650 CFM	Variable to 500 CFM	Variable to 1,000 CFM
Primary Filter	Electrostatic	Electrostatic	Electrostatic	Electrostatic	Disposable media	Disposable media
Cabinet	16 gauge steel cabinet with powder coated chemical resistant baked enamel, available in grey textured finish	18 gauge steel cabinet with powder coated chemical resistant baked enamel, available in grey textured finish	16 gauge steel cabinet with powder coated chemical resistant baked enamel, available in grey textured finish	16 gauge steel cabinet with powder coated chemical resistant baked enamel, available in grey textured finish	16 gauge steel cabinet with powder coated chemical resistant baked enamel, available in grey textured finish	16 gauge steel cabinet with powder coated chemical resistant baked enamel, available in grey textured finish
Power Input	115 VAC, 60 Hz, 1 ph, 2.5 A 240 VAC, 60 Hz, 1 ph, 1.25 A 460 VAC, 60 Hz, 1 ph, 0.63 A (connects to 2 legs of 460 VAC 3 ph)	115 VAC, 60 Hz, 1 ph, 3.9 A 240 VAC, 60 Hz, 1 ph, 1.95 A 460 VAC, 60 Hz, 1 ph, 0.98 A (connects to two legs of 460 VAC 3 ph)	115 VAC, 60 Hz, 1 ph, 4.3 A 240 VAC, 60 Hz, 1 ph, 2.15 A 460 VAC, 60 Hz, 1 ph, 1.08 A (connects to 2 legs of 460 VAC 3 ph)	115 VAC, 60 Hz, 1 ph, 8.2 A 240 VAC, 60 Hz, 1 ph, 4.1 A	115 VAC 60 Hz, 1 ph, 3.5 A 240 VAC, 60 Hz, 1 ph, 1.75 A	115 VAC, 60 Hz, 1 ph, 9.5 A 240 VAC, 60 Hz, 1 ph, 4.75 A
Efficiency	Ultimate efficiency up to 97.8% on all submicron particles as measured by independent lab test in accordance with ASHRAE standard 52.2 at 500 CFM	Ultimate efficiency up to 98.6% on all submicron particles as measured by independent lab test in accordance with ASHRAE standard 52.2 at 600 CFM	Ultimate efficiency up to 99.4% on all submicron particles as measured by independent lab test in accordance with ASHRAE standard 52.2 at 750 CFM	Ultimate efficiency up to 99.6% on all submicron particles as measured by independent lab test in accordance with ASHRAE standard 52.2 at 1,000 CFM	95% MERV 15 Filter	95% MERV 14 Filter
Filtration Stages	1st Stage: 4" aluminum mesh impinger 2nd Stage: AQE Advantage™ electronic cell (long life) 3rd Stage: Optional HEPA filter 99.97% efficiency, ESF filter, or carbon module	1st Stage: 4" aluminum mesh impinger 2nd Stage: AQE Advantage™ electronic cell (long life) 3rd Stage: MistBuster® electronic cell (high-efficiency) 4th Stage: Optional HEPA filter 99.97% efficiency, ESF filter, or carbon module	1st Stage: 4" aluminum mesh impinger 2nd Stage: AQE Advantage™ electronic cell (long life) 3rd Stage: MistBuster® electronic cell (high efficiency) 4th Stage: Optional MistBuster® electronic cell (high efficiency) 5th Stage: Optional HEPA filter 99.97% efficiency, ESF filter, or carbon module	1st Stage: 4" aluminum mesh impinger 2nd Stage: Two AQE Advantage™ electronic cells (long life) 3rd Stage: Two MistBuster® electronic cells (high efficiency) 4th Stage: Two optional MistBuster® electronic cells (high efficiency) 5th Stage: Optional HEPA filter 99.97% efficiency, or ESF filter module	1st Stage: 4" aluminum mesh impinger 2nd Stage: 95% efficient MERV 15 pleated filter 3rd Stage: Optional HEPA filter 99.97% efficiency, ESF filter, or carbon module	1st Stage: 4" aluminum mesh impinger 2nd Stage: 58 sq. ft. of lofted micro-fine fiberglass media 3rd Stage: Optional HEPA filter 99.97% efficiency, ESF filter, or carbon module

Air Quality Engineering, Inc. stands behind the quality of its MistBuster® product line with a limited 36-month warranty.

Specifications subject to change without notice

Advantage electronic collector cell
Optional high-efficiency electronic collector cell



4" aluminum mesh impinger
High-efficiency electronic collector cell

Unique geometry of motorized impeller reduces energy losses

The unique geometry of the motorized impeller improves aerodynamic efficiency, lowers energy losses and reduces noise. Because of its improved efficiency and performance, the impeller complies with the European Union's stringent Energy related Products (ErP) Directive to reduce CO2 emissions by developing more efficient products. The impeller is CE compliant and carries both the ErP and CE marks.



Extended electronic collector cell life

Advantage™ electronic collector cell greatly reduces the tendencies of high-efficiency electronic collector cells to short circuit. The patented cell design features grounded collection fins that extend further than positively charged repellent fins. The difference in fin lengths prevents positively charged droplets from bridging the conductive space between grounded and positively charged fins. This subtle change reduces the need to wash cells due to short circuiting and extends the life of electronic collector cells.

The Patented unique collector fin design in 2002, patent #6428611. Visit air-quality-eng.com/mist-collector-video to watch a video on the electronic cell technology.

Simply switch between watersoluble and oil-based coolants



The easy-to-use and patented water/oil selector switch adjusts the electrical properties of a MistBuster® system to match the type of coolant being used in a machine tool. The switch technology also helps to minimize the nuisance

arcing that may occur when using water-based coolants. The variable voltage coolant selector in 2010, has been patented, patent #7717984. To learn more about the technology of our water/oil selector switch, visit Brown & Holmes MistBuster® website. MistBuster® Features Focus on Performance

Easy access to side-panel electrical compartment

The MistBuster® product line features quarter-turn fasteners that cannot be overly tightened. The quickrelease fasteners facilitate fast and easy removal of the side-panel door and quick access to the electrical compartment, and reduce service and repair time.

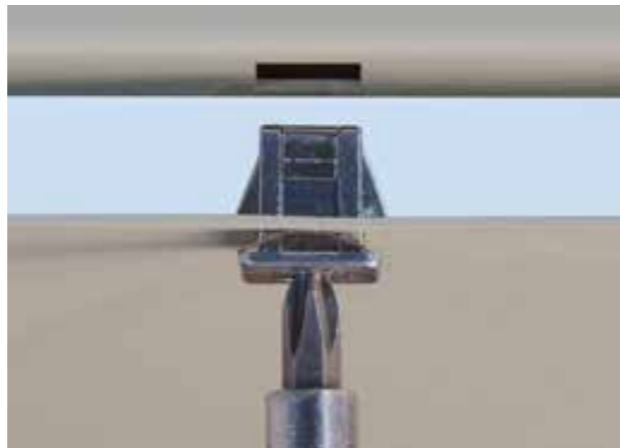

Door and gasket profile increases door-to-seal contact

The MistBuster® product line features a door and interior gasket profile that increases the door-to-seal contact. The industrial seal prevents coolant from leaking or pooling inside the door. Door-latch spacers prevent over-compression of the gasket and extend gasket life.



Variable-speed controller saves you energy and money

The variable-speed controller used with the MistBuster® product line helps you control the airflow rate needed to maintain the right amount of negative pressure to keep contaminants contained. If the rate is too low, contaminants can migrate outside of your machine tool into the shop. If the rate is too high, contaminants that would have otherwise collected or drained back into the machine tool are drawn into the air cleaner. In addition to precisely controlling the airflow rate, the variablespeed controller saves energy and reduces noise.

Increase your mounting and ducting options

Machine shops and facilities vary in size and the space available for installing air filtration systems. To make the most efficient use of the area available in your facility or plant, We offer a variety of mounting and ducting accessories that complement the MistBuster® product line. Our lineup of MistBuster® mounting options includes:

- *Direct* — unit is mounted directly on top of a machine tool, no additional ducting or accessories required
- *Pedestal stand* — unit is mounted on a floor stand and ducted to a machine tool
- *Machine mount stand* — unit is mounted on a machine tool with the stand, which allows for ducting to other sections of the machine tool enclosure
- *Ceiling or wall*

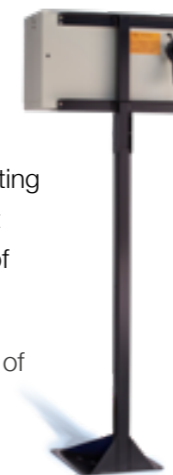

Safely and effectively wash electronic collector cells

The MistBuster® Total Cell Cleaner is a specially designed and highly effective detergent for cleaning electrostatic precipitator collector cells. The cleaning solution works on all types of machine tool coolant fluids, including petroleum-based cutting oils, water-soluble coolants and synthetics. For best results on tough-to-clean fluids,



mix the liquid concentrate with warm water and wash the electronic cell in an appropriately sized container available from Brown & Holmes.

- Safely cleans aluminum electronic collector cells
- Non-toxic and biodegradable
- Environmentally safe — no glycol ethers, hazardous air pollutants (HAPs) or volatile organic compounds (VOCs)
- Available in a gallon, 4-gallon cases and 5-gallon pails



An electrostatic precipitation air cleaning system for the The Range and removal of mist, smoke and metal particles produced by machine tool operations. In the MistBuster® family of products, the system supplies a lower spindle speed and coolant pressure (0–600 PSI).

The MistBuster® 500 three-stage air filtration system features Air Quality Engineering, Inc.'s patented Advantage™ electronic collector cell and a collection efficiency of up to 97.8% on all submicron particles. Airflow is variable and controllable up to 500 CFM. Easily switch between watersoluble or oil-based machine tool coolants using Air Quality Engineering, Inc.'s patented variable voltage coolant selector.



Machining applications

- Metal machining
- Grinding/polishing
- EDM mist collectors

Specifications

Airflow	Variable to 500 CFM	
Cabinet	16 gauge steel cabinet with powder coated chemical resistant baked enamel, available in grey textured finish	
Power Input	115 VAC, 60 Hz, 1 ph, 2.5 A 240 VAC, 60 Hz, 1 ph, 1.25 A 460 VAC, 60 Hz, 1 ph, 0.63 A (connects to 2 legs of 460 VAC, 3 ph)	
Efficiency	Ultimate efficiency up to 97.8% on all submicron particles as measured by independent lab test in accordance with ASHRAE standard 52.2 at 500 CFM	
Filtration Stages	<p>1st Stage: 4" aluminum mesh impinger</p> <p>2nd Stage: AQE Advantage™ electronic cell (long life)</p>	<p>3rd Stage: Optional HEPA filter 99.97% efficiency, ESF filter, or carbon module</p>
Features and Benefits	<ul style="list-style-type: none"> • Energy-efficient, self-regulating, dual-voltage, solid-state power supply • Patented water/oil coolant selector for a wider range of application compatibility • Patented electronic cell design that helps decrease service intervals • ErP-compliant, backward-curved, vibration-free, direct drive motorized impeller rated at 500 CFM @ 1.3" w.g. provides energy-efficient operation and increased performance to save on operating costs while performing well with increased airflow resistance from post filter or long duct lengths 	<ul style="list-style-type: none"> • Ten-foot power cord with molded plug • Quick-release, quarter-turn fasteners for fast, easy side-panel electrical compartment access reduces service and repair time • Door and gasket profile increases door-to-seal contact to prevent leakage and pooling of coolant inside of door • Door-latch spacers prevent over-compression of the gasket and increase gasket life

Air Quality Engineering, Inc. stands behind the quality of its MistBuster® product line with a limited 36-month warranty. Specifications subject to change without notice

Specifications

Dimensions	690mm L x 355mm W x 440mm H	
Inlet Opening	425mm x 230mm	
Weight	30Kg	
Accessories	Machine mount stand Pedestal stand Ceiling mount kit Wall mount kit	Plenum Diffuser HEPA post filter ESF post filter Carbon module

Specifications subject to change without notice

Dimensions*

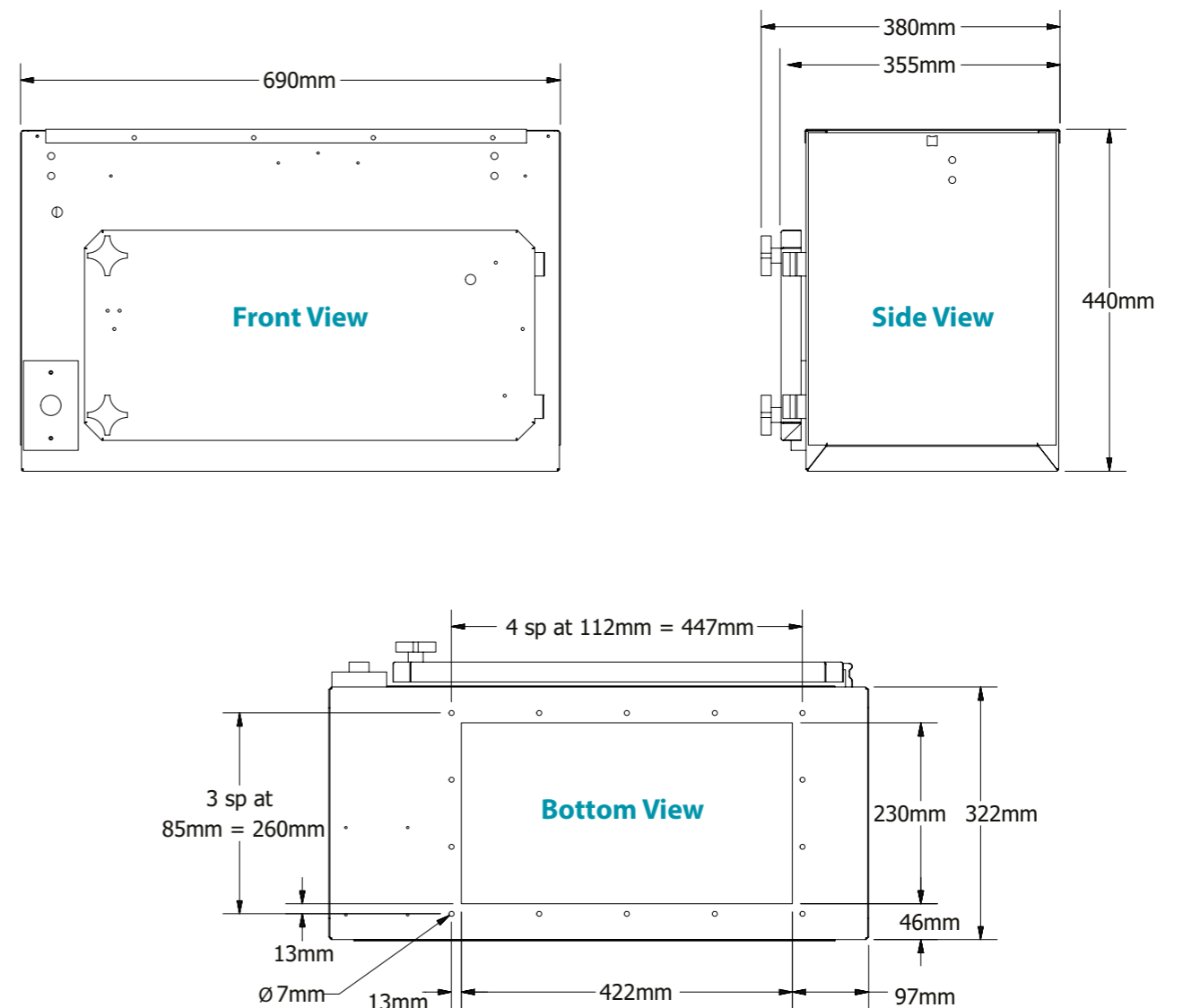



A compact version of the MistBuster® 850 electrostatic precipitation air cleaning system for the source capture and removal of smoke, mist and metal particles generated by today's machining applications. In the MistBuster® product family, the system provides a higher spindle speed and coolant pressure (600–1,500 PSI).

The MistBuster® 850 Compact four-stage air filtration system features Air Quality Engineering, Inc.'s patented Advantage™ electronic collector cell and an additional high-efficiency electronic collector cell. The electronic collector cells provide a collection efficiency up to 98.6% on all submicron particles. Using Air Quality Engineering, Inc.'s patented variable voltage coolant selector, simply switch between water-soluble or oil-based machine tool coolants. Airflow is variable and controllable up to 850 CFM.

Machining applications

- Metal machining
- EDM mist collectors
- Grinding/polishing

Specifications

Airflow	Variable to 850 CFM	
Cabinet	18 gauge steel cabinet with powder coated chemical resistant baked enamel, available in grey textured finish	
Power Input	115 VAC, 60 Hz, 1 ph, 3.9 A 240 VAC, 60 Hz, 1 ph, 1.95 A 460 VAC, 60 Hz, 1 ph, 0.98 A (connects to two legs of 460 VAC, 3 ph)	
Efficiency	Ultimate efficiency up to 97.8% on all submicron particles as measured by independent lab test in accordance with ASHRAE standard 52.2 at 500 CFM	
Filtration Stages	<p>1st Stage: 4" aluminum mesh impinger</p> <p>2nd Stage: AQE Advantage™ electronic cell (long life)</p>	<p>3rd Stage: Optional HEPA filter 99.97% efficiency, ESF filter, or carbon module</p>
Features and Benefits	<ul style="list-style-type: none"> • Energy-efficient, self-regulating, dual-voltage, solid-state power supply • Patented water/oil coolant selector for a wider range of application compatibility • Patented electronic cell design that helps decrease service intervals • ErP-compliant, backward-curved, vibration-free, direct drive motorized impeller rated at 500 CFM @ 1.3" w.g. provides energy-efficient operation and increased performance to save on operating costs while performing well with increased airflow resistance from post filter or long duct lengths 	<ul style="list-style-type: none"> • Ten-foot power cord with molded plug • Quick-release, quarter-turn fasteners for fast, easy side-panel electrical compartment access reduces service and repair time • Door and gasket profile increases door-to-seal contact to prevent leakage and pooling of coolant inside of door • Door-latch spacers prevent over-compression of the gasket and increase gasket life

Air Quality Engineering, Inc. stands behind the quality of its MistBuster® product line with a limited 36-month warranty. Specifications subject to change without notice

Specifications

Dimensions	690mm L x 355mmW x 570mm H	
Inlet Opening	422mm x 230mm	
Weight	45kg	
Accessories	Machine mount stand Pedestal stand Ceiling mount kit Wall mount kit	Plenum Diffuser HEPA post filter ESF post filter Carbon module

Specifications subject to change without notice

Dimensions*

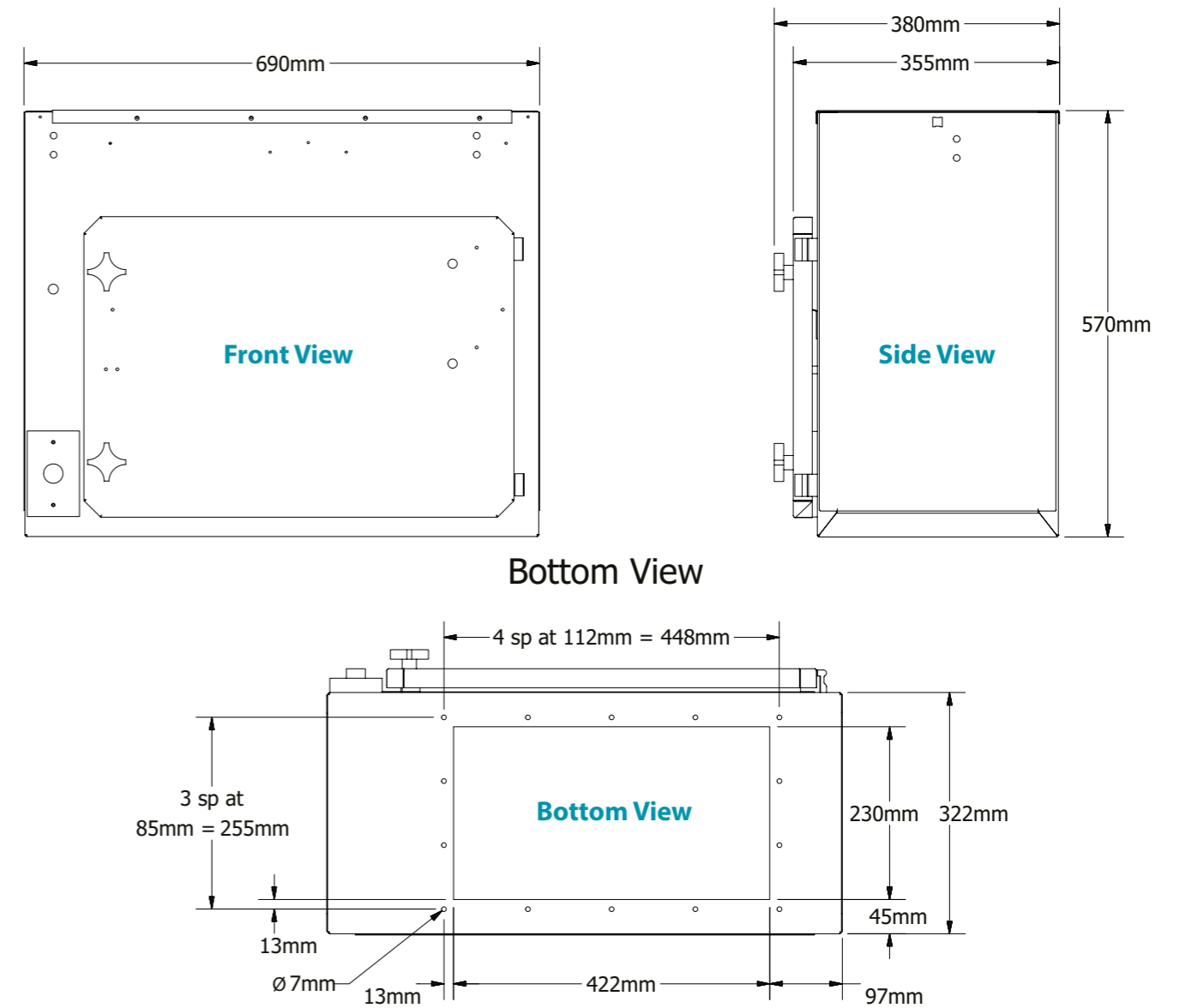



An electrostatic precipitation air cleaning system for the The Range and removal of smoke, mist and metal particle contaminants produced from machine tool coolant fluids. In the MistBuster® family of products, the system supplies a higher spindle speed and coolant pressure (600–1,500 PSI).

The MistBuster® 850 five-stage air filtration system features Air Quality Engineering, Inc.'s patented Advantage™ electronic collector cell and one or two high-efficiency electronic collector cells. The electronic collector cells provide a collection efficiency up to 99.4% on all submicron particles. An optional fifth-stage HEPA filter offers filtration efficiency up to 99.97%. Airflow is variable and controllable up to 850 CFM. Easily switch between water-soluble or oil-based machine tool coolants using Air Quality Engineering, Inc.'s patented variable voltage coolant selector.

Machining applications

- Metal machining
- EDM mist collectors
- Grinding/polishing

Specifications

Airflow	Variable to 850 CFM	
Cabinet	16 gauge steel cabinet with powder coated chemical resistant baked enamel, available in grey textured finish	
Power Input	115 VAC, 60 Hz, 1 ph, 4.3 A 240 VAC, 60 Hz, 1 ph, 2.15 A 460 VAC, 60 Hz, 1 ph, 1.08 A (connects to 2 legs of 460 VAC, 3 ph)	
Efficiency	Ultimate efficiency up to 99.4% on all submicron particles as measured by independent lab test in accordance with ASHRAE standard 52.2 at 750 CFM	
Filtration Stages	<p>1st Stage: 4" aluminum mesh impinger</p> <p>2nd Stage: AQE Advantage™ electronic cell (long life)</p> <p>3rd Stage: MistBuster® electronic cell (high efficiency)</p>	<p>4th Stage: Optional MistBuster® electronic cell (high efficiency)</p> <p>5th Stage: Optional HEPA filter 99.97% efficiency, ESF filter, or carbon module</p>
Features and Benefits	<ul style="list-style-type: none"> • Two energy-efficient, self-regulating, dual-voltage, solid-state power supplies • Patented water/oil coolant selector for a wider range of application compatibility • Patented electronic cell design that helps decrease service intervals • ErP-compliant, backward-curved, vibration-free, direct drive motorized impeller rated at 850 CFM @ 1.1" w.g. provides energy-efficient operation and increased performance to save on operating costs while performing well with increased airflow resistance from post filter or long duct lengths 	<ul style="list-style-type: none"> • Ten-foot power cord with molded plug • Quick-release, quarter-turn fasteners for fast, easy side-panel electrical compartment access reduces service and repair time • Door and gasket profile increases door-to-seal contact to prevent leakage and pooling of coolant inside of door • Door-latch spacers prevent over-compression of the gasket and increase gasket life

Air Quality Engineering, Inc. stands behind the quality of its MistBuster® product line with a limited 36-month warranty. Specifications subject to change without notice

Specifications

Dimensions	690mm L x 355mm W x 698mm H	
Inlet Opening	425mm x 230mm	
Weight	45kg	
Accessories	Machine mount stand Pedestal stand Ceiling mount kit Wall mount kit	Plenum Diffuser HEPA post filter ESF post filter Carbon module

Specifications subject to change without notice

Dimensions*

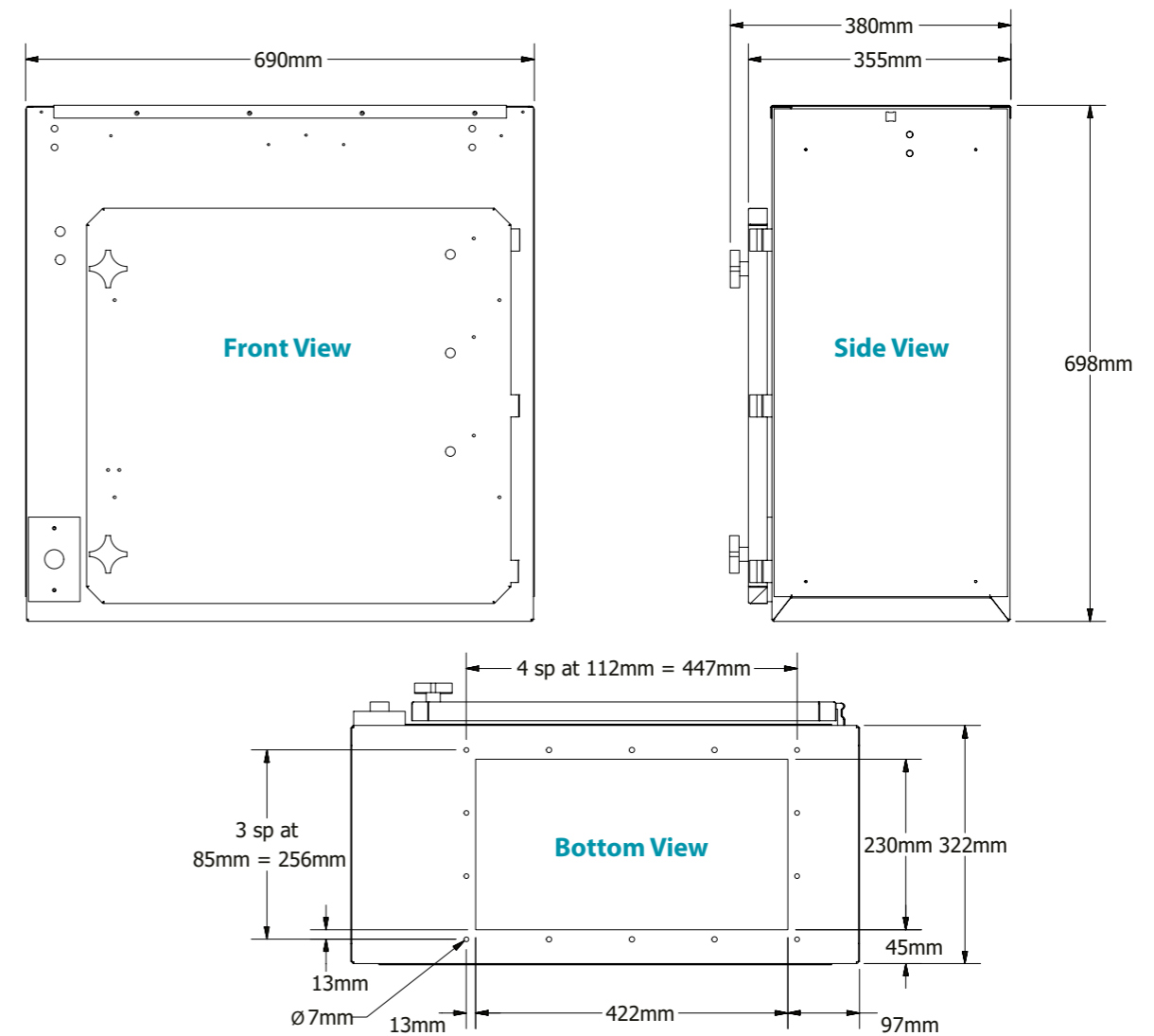



An electrostatic precipitation air cleaning system for the The Range and removal of smoke, mist and metal particle contaminants produced from machine tool coolant fluids. In the MistBuster® family of products, the system supplies a higher spindle speed and coolant pressure (600–1,500 PSI).

The MistBuster® 850 five-stage air filtration system features Air Quality Engineering, Inc.'s patented Advantage™ electronic collector cell and one or two high-efficiency electronic collector cells. The electronic collector cells provide a collection efficiency up to 99.4% on all submicron particles. An optional fifth-stage HEPA filter offers filtration efficiency up to 99.97%. Airflow is variable and controllable up to 850 CFM. Easily switch between water-soluble or oil-based machine tool coolants using Air Quality Engineering, Inc.'s patented variable voltage coolant selector.

Machining applications

- Metal machining
- EDM mist collectors
- Grinding/polishing

Specifications

Airflow	Variable to 1,650 CFM	
Cabinet	16 gauge steel cabinet with powder coated chemical resistant baked enamel, available in grey textured finish	
Power Input	115 VAC, 60 Hz, 1 ph, 8.2 A 240 VAC, 60 Hz, 1 ph, 4.1 A	
Efficiency	Ultimate efficiency up to 99.4% on all submicron particles as measured by independent lab test in accordance with ASHRAE standard 52.2 at 750 CFM	
Filtration Stages	<p>1st Stage: 4" aluminum mesh impinger</p> <p>2nd Stage: AQE Advantage™ electronic cell (long life)</p> <p>3rd Stage: MistBuster® electronic cell (high efficiency)</p>	<p>4th Stage: Optional MistBuster® electronic cell (high efficiency)</p> <p>5th Stage: Optional HEPA filter 99.97% efficiency, ESF filter, or carbon module</p>

- | | | |
|------------------------------|---|---|
| Features and Benefits | • Two energy-efficient, self-regulating, dual-voltage, solid-state power supplies | • Ten-foot power cord with molded plug |
| | • Patented water/oil coolant selector for a wider range of application compatibility | • Quick-release, quarter-turn fasteners for fast, easy side-panel electrical compartment access reduces service and repair time |
| | • Patented electronic cell design that helps decrease service intervals | • Door and gasket profile increases door-to-seal contact to prevent leakage and pooling of coolant inside of door |
| | • ErP-compliant, backward-curved, vibration-free, direct drive motorized impeller rated at 850 CFM @ 1.1" w.g. provides energy-efficient operation and increased performance to save on operating costs while performing well with increased airflow resistance from post filter or long duct lengths | • Door-latch spacers prevent over-compression of the gasket and increase gasket life |

Air Quality Engineering, Inc. stands behind the quality of its MistBuster® product line with a limited 36-month warranty. Specifications subject to change without notice

Specifications

Dimensions	660mm L x 675mm W x 700mm H	
Inlet Opening	406mm x 530mm	
Weight	95kg	
Accessories	Machine mount stand Pedestal stand Ceiling mount kit Wall mount kit	Plenum Diffuser HEPA post filter ESF post filter

Specifications subject to change without notice

Dimensions*

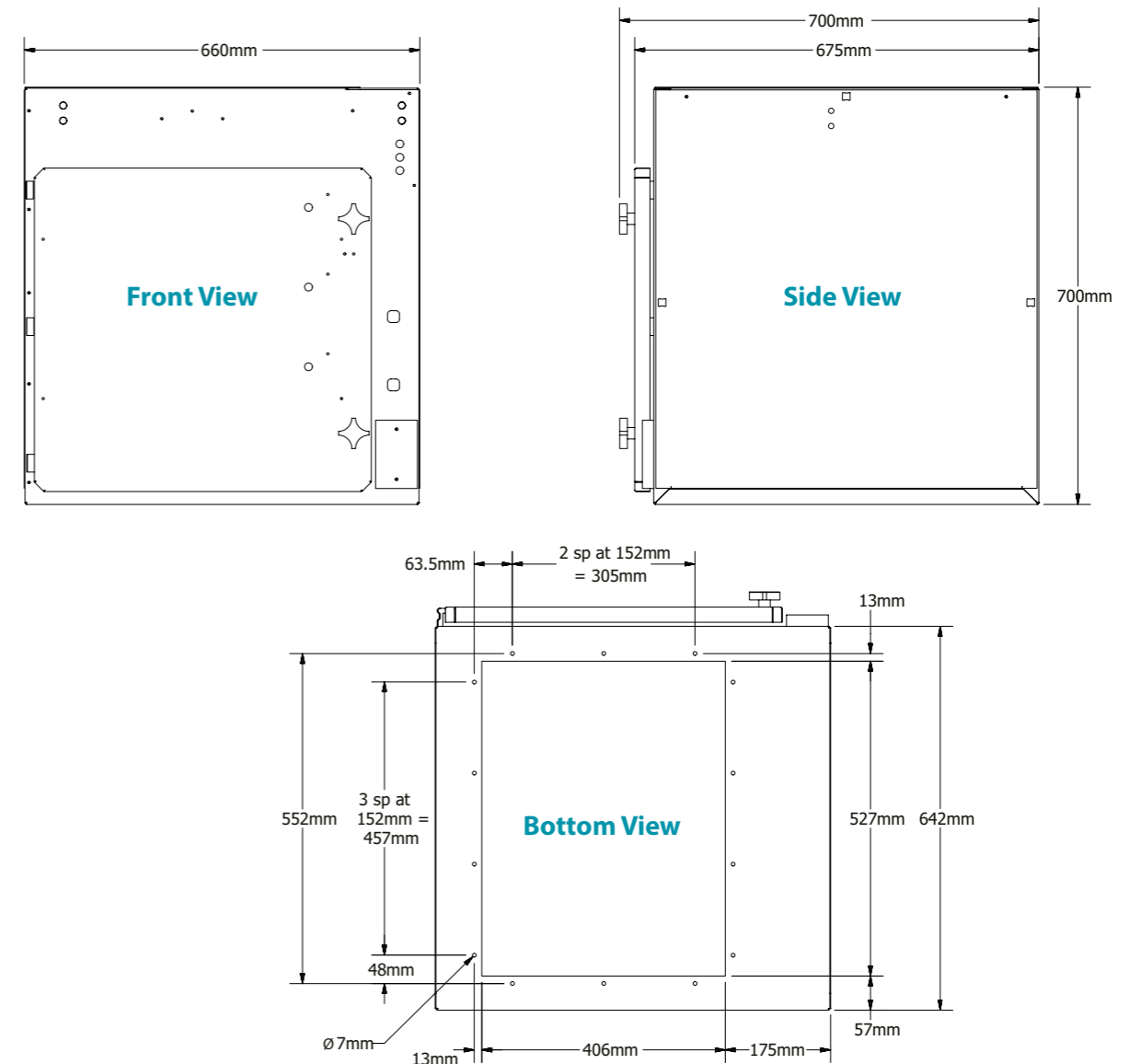



A media-based air cleaning system for the The Range of smoke, mist and metal particles produced by machining applications. The system uses a second-stage MERV 15 pleated filter.

The MistBuster® 500 Media three-stage air cleaning system provides up to 95% collection efficiency using a disposable MERV 15 pleated filter.

Airflow is variable and controllable up to 500 CFM.

Machining applications

- Metal machining
- EDM mist collectors
- Grinding/polishing

Specifications

Airflow	Variable to 500 CFM	
Cabinet	16 gauge steel cabinet with powder coated chemical resistant baked enamel, available in grey textured finish	
Power Input	115 VAC 60 Hz, 1 ph, 3.5 A 240 VAC, 60 Hz, 1 ph, 1.75 A	
Efficiency	95% MERV 15 Filter	
Filtration Stages	1st Stage: 4" aluminum mesh impinger 2nd Stage: 95% efficient MERV 15 pleated filter	3rd Stage: Optional HEPA filter 99.97% efficiency, ESF filter, or carbon module
Features and Benefits	<ul style="list-style-type: none"> • ErP-compliant, backward-curved, vibration-free, direct drive motorized impeller rated at 500 CFM @ 2.5" w.g. provides energy-efficient operation and increased performance to save on operating costs while performing well with increased airflow resistance from post filter or long duct lengths • Ten-foot power cord with molded plug 	<ul style="list-style-type: none"> • Quick-release, quarter-turn fasteners for fast, easy side-panel electrical compartment access reduces service and repair time • Door and gasket profile increases door-to-seal contact to prevent leakage and pooling of coolant inside of door • Door-latch spacers prevent over-compression of the gasket and increase gasket life

Air Quality Engineering, Inc. stands behind the quality of its MistBuster® product line with a limited 36-month warranty. Specifications subject to change without notice

Specifications

Dimensions	690mm L x 355mm W x 440mm H	
Inlet Opening	420mm x 230mm	
Weight	27Kg	
Accessories	Machine mount stand Pedestal stand Ceiling mount kit Wall mount kit	Plenum Diffuser HEPA post filter ESF post filter Carbon module

Specifications subject to change without notice

Dimensions*

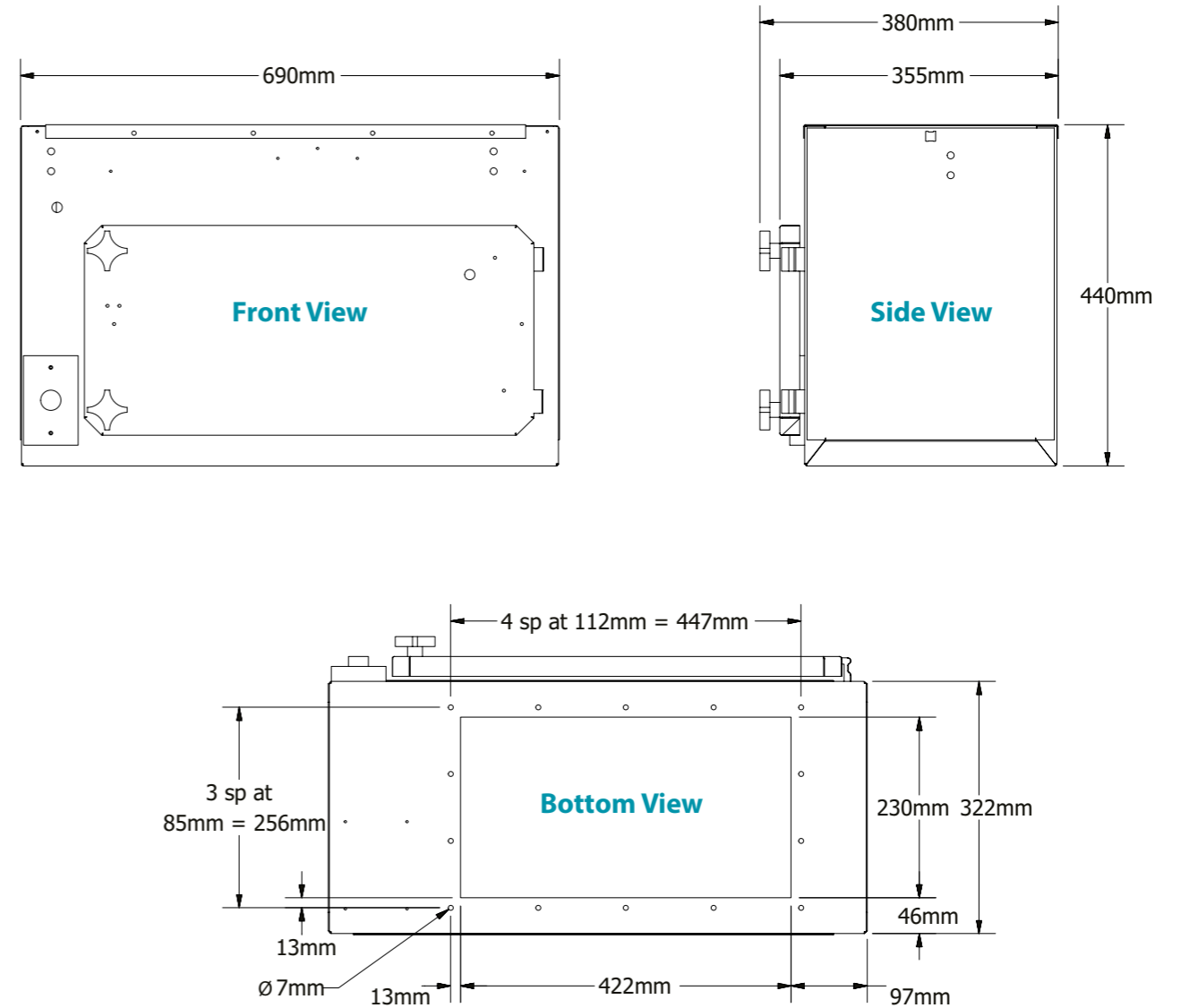



A media-based air filtration system for the collection and removal of mist, smoke and metal particles produced by machine tool operations. The system uses 58 sq. ft. of lofted micro-fine fiberglass media in its second filtration stage.

The MistBuster® Infinity three-stage air cleaning system provides up to 95% MERV 14 filter collection efficiency and is ideal for cast iron machining applications. An optional third-stage HEPA filter offers filtration efficiency up to 99.97%. Airflow is variable and controllable up to 1,000 CFM.M.



Machining applications

- Metal machining
- EDM mist collectors
- Grinding/polishing

Specifications

Airflow	Variable to 1000 CFM	
Cabinet	16 gauge steel cabinet with powder coated chemical resistant baked enamel, available in grey textured finish	
Power Input	115 VAC, 60 Hz, 1 ph, 9.5 A 240 VAC, 60 Hz, 1 ph, 4.75 A	
Efficiency	95% MERV 15 Filter	
Filtration Stages	<p>1st Stage: 4" aluminum mesh impinger</p> <p>2nd Stage: 58 sq. ft. of lofted micro-fine fiberglass media</p>	<p>3rd Stage: Optional HEPA filter 99.97% efficiency, ESF filter, or carbon module</p>
Features and Benefits	<ul style="list-style-type: none"> • Backward-curved, vibration-free, direct drive motorized impeller rated at 1,000 CFM @ 3.0" w.g. provides energy-efficient operation and increased performance to save on operating costs while performing well to obtain full life out of the media filters while overcoming the resistance of duct • Standard size prefilter and main filter track size allows for the use of a variety of filter media for a wide range of applications 	<ul style="list-style-type: none"> • Ten-foot power cord with molded plug • Dirty filter gauge for easy monitoring of filter status • Infinitely variable fan speed controller provides easy airflow adjustment to obtain the desired airflow for your application

Air Quality Engineering, Inc. stands behind the quality of its MistBuster® product line with a limited 36-month warranty. Specifications subject to change without notice

Specifications

Dimensions	690mm L x 670mm W x 805mm H	
Inlet Opening	565mm x 590mm	
Weight	85kg	
Accessories	Machine mount stand Pedestal stand Ceiling mount kit Wall mount kit	Plenum Diffuser HEPA post filter ESF post filter Carbon module Long life filter

Specifications subject to change without notice

Dimensions*

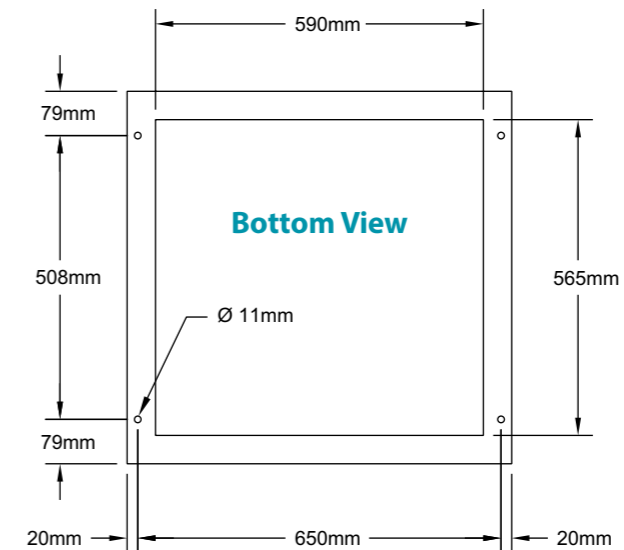
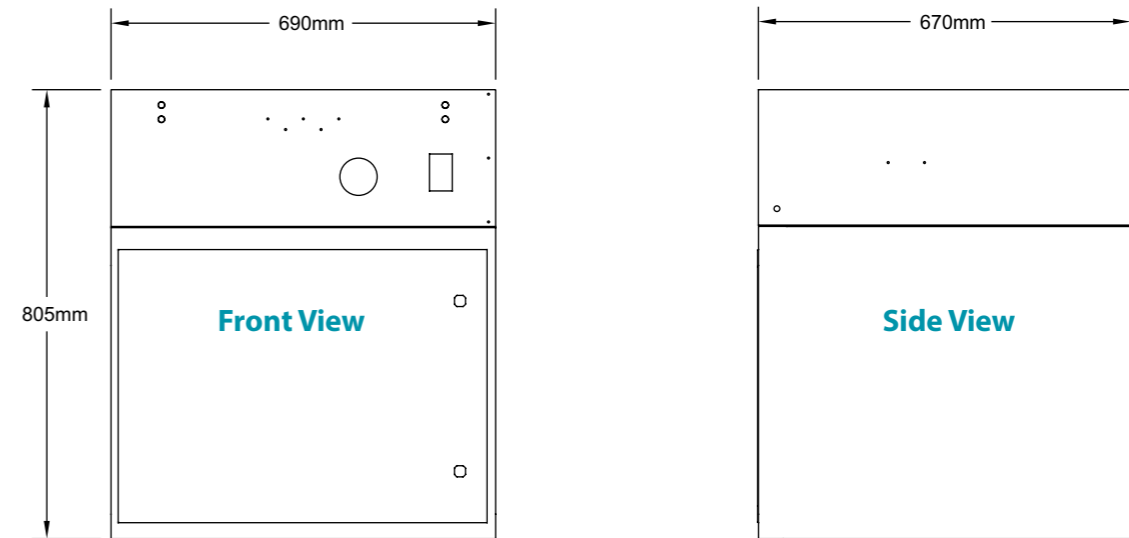

BROWN & HOLMES (Tamworth) LTD

Precision Workholding and Machining 

Brown & Holmes (Tamworth) LTD

Unit F, Apollo Park,
Lichfield Road Industrial Estate
Tamworth
Staffordshire B79 7TA

Tel: 01827 63591

Fax: 01827 54322

email:info@brownandholmes.co.uk

website:brownandholmes.co.uk

Connect with Brown and Holmes:

TWITTER: twitter.com/brownandholmes

LINKEDIN: [linkedin.com/company/brown-&-holmes-tamworth-ltd](https://www.linkedin.com/company/brown-&-holmes-tamworth-ltd)