

Fine Filtration System Core 1000 with IFDR technology

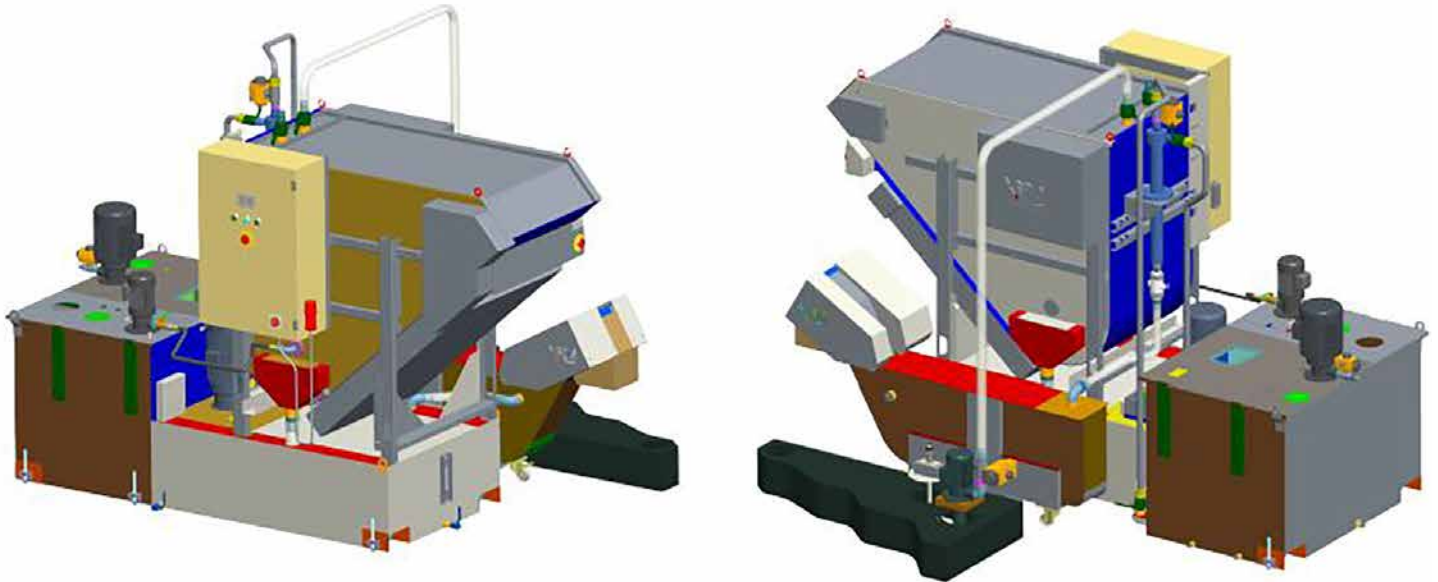

Advantages of CORE 1000

The CORE fine filtration system has been designed to provide a solution to problematic situations that are frequently found on machine tools. Moreover, it can be installed on new machines fitted with tanks and conveyors with unsuitable features for specific work.

In particular, it offers answers to the following problems:

- Presence of small chips in the tank with frequent pump clogging.
- Presence of floating oils, which prevent proper oxygenation, on the coolant surface.
- Need for less than 10 μm filtration degree for coolant to be sent to the machine tool spindle.

The CORE 1000 fine filtration system integrates three widely tested technologies in the RBM's constructive tradition, and precisely:

- The technology of our rotofilters with stainless steel drum and prefiltration at 50 μm .
- The FILSTAR technology – no filter elements to be replaced and disposed of – to guarantee fine filtration below 10 μm .
- IFDR technology to guarantee the dynamic separation of the oil and the correct oxygenation of the coolant.

The simplicity of assembly and functional management managed by an integrated PLC make this solution highly flexible and applicable to any machine tool.

Approval to the Machinery Directive and CE certification as a machine.

TECHNICAL FEATURES

Overall system volume	1.800 L
Processing flow rate 50 µm	350 L/min
Processing flow rate 10 µm	240 L/min
Coolant type Both synthetic and mineral coolant	Both synthetic and mineral coolant
Filstar unit	KML40
Clean coolant volume	1.000 L
Nominal factory space requirements (LxWxH)	4154 x 1629 x 3094 mm
Nominal empty weight	2.517 kg
Automatic sludge recovery	In a special tank
Dynamic separation of the oil	Automatic integrated
Dirty liquid suction pump	Standard
Electrical control panel with machine tool interface	Standard
Working cycle	Continuous 24/7
Guaranteed filtration degree	Below 50 µm for 100% of the coolant
Guaranteed filtration degree	Below 10 µm for delivery pumps
Chiller for temperature control	Optional
Automatic coolant top up	Integrated

